

Floor Mounted

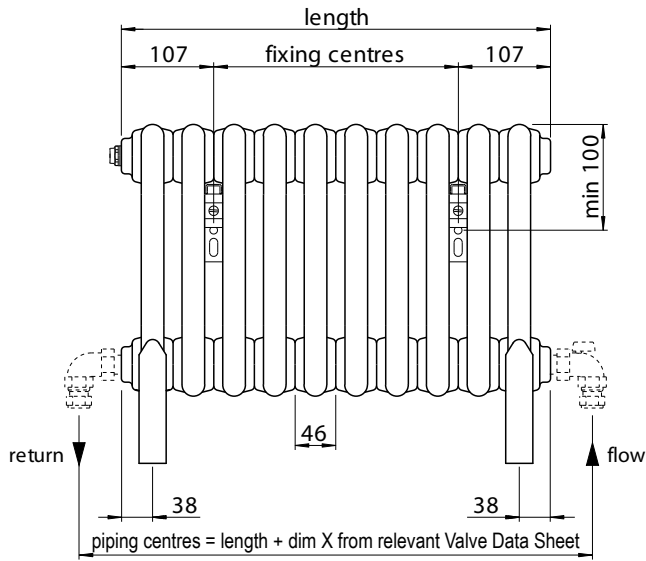

Note:
If fitting in an alcove
allow minimum of
100mm each side
for valves

* This dim may be reduced
by 5mm by turning the
bracket upside down

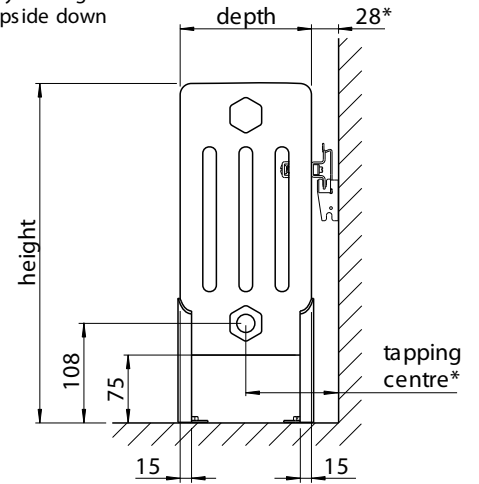

- Test pressure: 15 BAR
- Max working pressure: 10 BAR
- Max working temperature: 120° C
- All steel construction: 1.5mm header thickness
dia 25mm x 1.25mm tubes
- Connections: ½ inch BSP bottom opposite end tapping

All dimensions shown are in millimetres

Heat output determined in accordance with EN 442

Model	Output ÄT=50K Watts	Output ÄT=60K Watts	n	Water Content litres	Weight kg	Height ± 2mm	Length ± 2%	Depth ± 2mm	Tapping Centre* ± 2mm
4F-30-45	419	526	1.25	7.0	10	375	490	136	96
4F-30-72	670	842	1.25	11.2	16	375	766	136	96
4F-30-90	838	1052	1.25	14.0	20	375	950	136	96
4F-30-108	1006	1263	1.25	16.8	24	375	1134	136	96
4F-40-67	824	1036	1.26	13.5	21	475	720	136	96
4F-40-90	1098	1382	1.26	18.0	28	475	950	136	96
4F-40-108	1318	1658	1.26	21.6	34	475	1134	136	96
4F-40-135	1647	2072	1.26	27.0	42	475	1410	136	96
4F-50-54	811	1021	1.26	12.0	20	575	582	136	96
4F-50-63	946	1191	1.26	14.0	24	575	674	136	96
4F-50-72	1082	1361	1.26	16.0	27	575	766	136	96
4F-50-90	1352	1701	1.26	20.0	34	575	950	136	96
4F-50-108	1622	2041	1.26	24.0	41	575	1134	136	96
4F-50-126	1893	2382	1.26	28.0	48	575	1318	136	96
4F-60-45	798	1006	1.27	12.0	20	675	490	136	96
4F-60-63	1117	1408	1.27	16.8	28	675	674	136	96
4F-60-81	1436	1811	1.27	21.6	36	675	858	136	96
4F-60-99	1756	2213	1.27	26.4	44	675	1042	136	96
4F-60-117	2075	2615	1.27	31.2	52	675	1226	136	96
4F-75-27	584	737	1.27	8.4	15	825	306	136	96
4F-75-36	779	982	1.27	11.2	20	825	398	136	96
4F-75-54	1169	1473	1.27	16.8	30	825	582	136	96
4F-75-63	1364	1719	1.27	19.6	35	825	674	136	96
6F-30-108	1471	1851	1.26	26.4	38	375	1134	210	133
6F-40-108	1932	2435	1.27	31.2	48	475	1134	210	133
6F-40-135	2415	3044	1.27	39.0	60	475	1410	210	133