

Tools & Material Required

- Suitable valves
- PTFE tape
- Silicone thread sealant
- Tape measure
- Allen key - 2.5mm, 13mm & 12mm (when installing Bisque valves)
- Spanner - 22mm
- Screwdriver - large flathead
- Electric drill
- Masonry drill bit - 10mm diameter
- Spirit level
- Stepladder (for taller radiators)

Key	Component	Qty
A	Air Vent - 1/2"	1
B	Blanking Plug	1
C	Plastic Diverter	1
D	Plastic Key	1
E	Wall Plug	4
F	Bracket	4
G	Backing Plate	4
H	Screw - Rnd Head, 7mm dia x 70mm	4
I	Grub Screw	4
J	Protective Cover	1
K	Pin	1

Assembly Instructions for BOE Connections

Sufficient PTFE tape must be applied to valve-tail threads prior to their installation.  
Silicone thread sealant should be applied to all threaded components manufactured with 'O-rings'.

Fit air vent (A) finger tight in upper header (opposite to the flow-side tapping side). Place protective cover (J) over air vent (A) and tighten using pliers. Remove protective cover (J). Insert pin (K) into hole in air vent (A) and rotate until hole is at lowest point. Remove pin (K).

Fit blanking plug (B) to upper header (opposite air vent).

Insert diverter (C) into flow-side tapping.

Using key (D) screw diverter (C) fully into tapping. This will permit sufficient tapping for valve.

Fit valve tails, using correct size Allen key.

Accurately mark out bracket holes on wall using spirit level, to dimensions as shown on Technical Data Sheet.

Drill four 10mm diameter holes to a minimum depth of 65mm & insert wall plugs (E).

Screw brackets (F) with backing plates (G) to wall with screws (H).

Undo grub screws (I) with allen key.

Hang radiator onto brackets (F). Ensure that radiator is fully seated onto all four brackets, adjusting brackets (F) if necessary, and tighten grub screws (I).

Plumb radiator to heating circuit with flow opposite air vent.  
To ventilate, place a cloth or sponge under hole in air vent (A).  
Push button and release as soon as water exits hole.

(Refer to Connection Options sheet for possible connections and Technical Data Sheet TDS1.1 for venting procedure.)

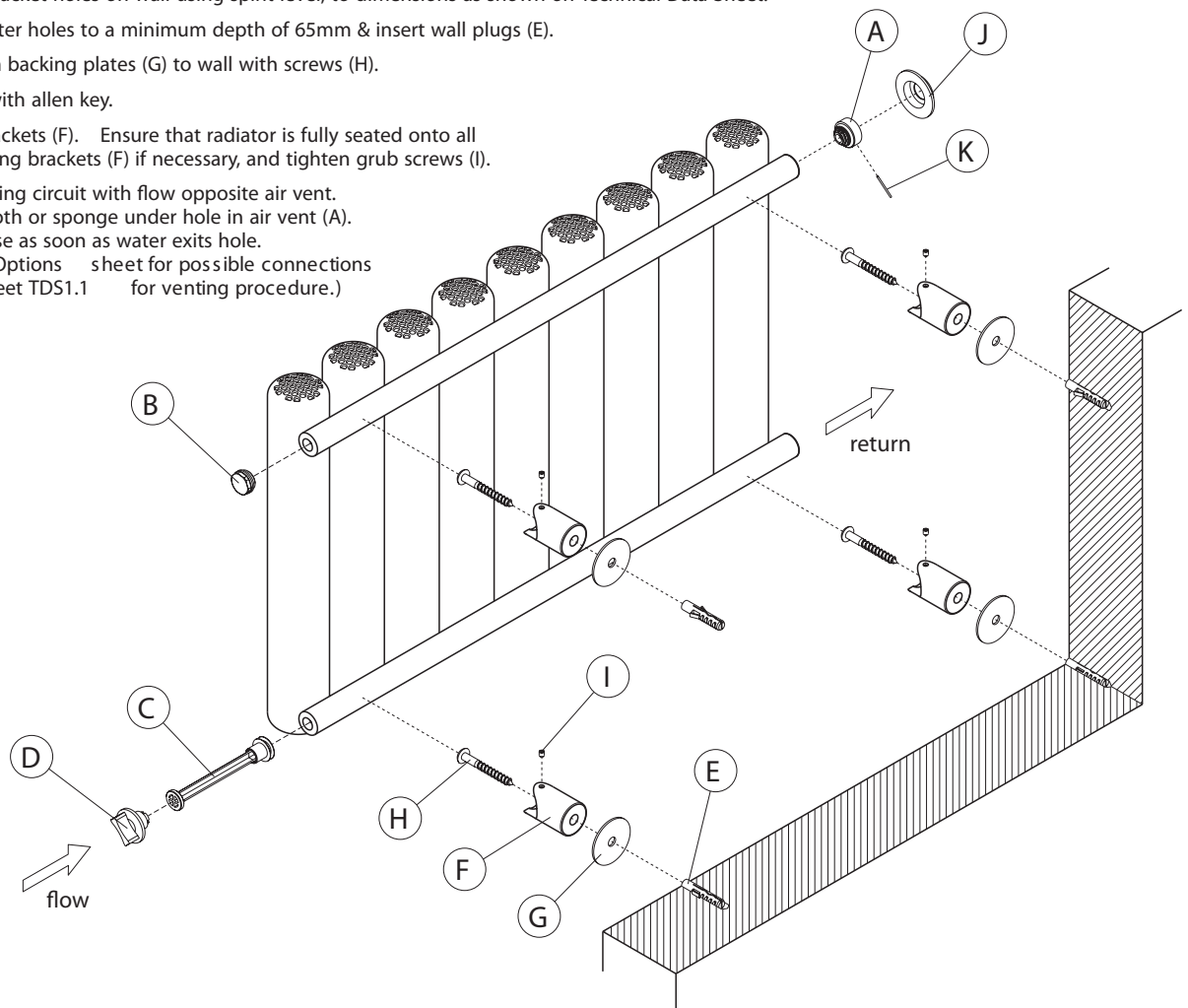

Possible Flow Connections

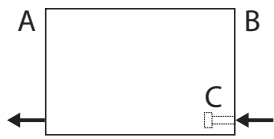

**BOE**  
bottom opposite end,  
side, right hand flow



**TBOE**  
top-bottom opposite end,  
side, right hand flow

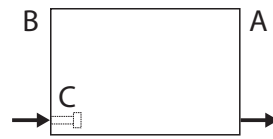

**BOE**  
bottom opposite end,  
side, left hand flow



**TBOE**  
top-bottom opposite end,  
side, left hand flow

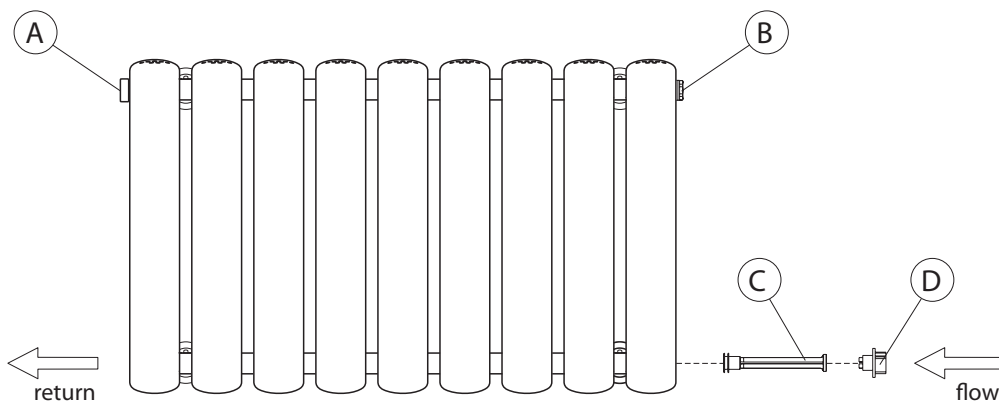

Key	Component
A	Air Vent - 1/2"
B	Blanking Plug
C	Plastic Diverter
D	Plastic Key

How to fit the Flow Diverter

- Insert the flow diverter (C) into the FLOW connection, pushing the blue rubber diaphragm in first.
- Use the key (D) to screw the flow diverter (A) fully into the connection, ensuring that enough thread is available to make a good connection for the valve tail.
- The air vent (A) should be connected to the top connection ON THE OPPOSITE SIDE to the flow diverter (i.e. If the flow diverter has been fitted bottom left, the air vent should be positioned top right).
- The other top connection on the same side of the radiator as the flow diverter (i.e. from the previous example it would be top left) must be sealed using the blanking plug (B) supplied.

Important Reminder

A flow diverter must only be fitted to the flow side when entering at the bottom of the radiator.

An air vent must always be fitted opposite the flow side, on the top connection.

Note: All radiators should be fully vented to ensure satisfactory operation (see sheet TDS1.1 Venting Procedure ).

